

Enrollment No: _____

Exam Seat No: _____

C. U. SHAH UNIVERSITY

Winter Examination-2022

Subject Name : Engineering Graphics & CAD

Subject Code : 4TE02EGC1

Branch: B.Tech (All)

Semester: 2

Date: 23/09/2022

Time: 11:00 To 02:00

Marks: 70

Instructions:

- (1) Use of Programmable calculator & any other electronic instrument is prohibited.
 - (2) Instructions written on main answer book are strictly to be obeyed.
 - (3) Draw neat diagrams and figures (if necessary) at right places.
 - (4) Assume suitable data if needed.
-

Q-1 Attempt the following questions: (14)

- a) A line of 1 meter is shown by 1cm on a scale. Its Representative fraction (RF) is
- (a) 1 (b) 100
(c) 1/100 (d) 1/50
- b) Which of the following represent enlarged scale?
- (a) 1:1 (b) 1:2
(c) 2:1 (d) 1:10
- c) A right regular hexagonal prism is resting on HP on its base, its top view is a
- (a) Square (b) Rectangle
(c) Hexagon (d) Pentagon
- d) Which of the following position is not possible for a plane?
- (a) Perpendicular to both HP and VP
(b) Parallel to both HP and VP
(c) Perpendicular to HP and parallel to VP
(d) Perpendicular to VP and parallel to HP
- e) Second angle projection is not used because
- (a) both views overlap each other (b) Plan is above xy
(c) elevation is above xy (d) views are small in size
- f) The angle between isometric axis is
- (a) 30° (b) 90°
(c) 120° (d) 180°
- g) If a solid is cut by a cutting plane parallel to the base of the solid and top part is removed, the remaining part is called
- (a) Frustum of a solid (b) Truncated solid
(c) Oblique solid (d) None of the above
- h) A cylinder can be created by drawing a rectangular shape using the _____ tool.
- (a) Revolve (b) Sweep
(c) Extrude (d) none of the above.



- i) The curve generated by a point on the circumference of a circle, which rolls without slipping along outside of another circle is known as
 (a) Hypocycloid (b) Epicycloid
 (c) Cycloid (d) Trochoid
- j) A right circular cone resting on HP on its base is cut by a section plane parallel to HP, bisecting its axis. The true shape of the section is
 (a) Parabola (b) Hyperbola
 (c) Ellipse (d) Circle
- k) The development of lateral surfaces of a pentagonal pyramid is
 (a) Five squares (b) Five Rectangles
 (c) Five triangles (d) None of these
- l) The isometric projection of a circle is a
 (a) Circle (b) Ellipse
 (c) Hyperbola (d) Parabola
- m) A point P is above Horizontal Plane (HP) and in front of Vertical Plane (VP). The point is in
 (a) First quadrant (b) Second quadrant
 (c) Third quadrant (d) Fourth quadrant
- n) When the line is parallel to both Horizontal Plane (HP) and Vertical Plane (VP), we can get its true length in
 (a) Front view (b) Top view
 (c) Both a and b (d) Side view

Attempt any four questions from Q-2 to Q-8

Q-2 Attempt all questions (14)

A Define R.F. Construct a plain scale of R.F. 1:100 to show meters and decimeters. Maximum measurement required is 10 meters. Indicate 8 m 7 dm on the scale. 07

B In following Figure - 1 OBA is a simple slider crank chain. OB is a crank of 30 mm length. BA is a connecting rod of 90 mm length. Slider A is sliding on a straight path passing through point O. Draw the locus of the mid-point of the connecting rod AB for one complete revolution of the crank OB. 07

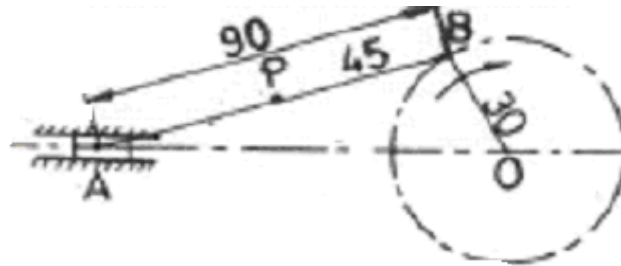

Fig. 1

Q-3 Attempt all questions (14)

A Draw and name the curve traced by a point on the perimeter of 60 mm diameter circle if it rolls by one revolution outside the circle with 160 mm diameter. 07

B Draw the projections of a circle 70mm diameter resting on the H.P. on a point A of the circumference. Plane is inclined to the H.P. such that the 07



plan of it is an ellipse of minor axis 40 mm. The plan of the diameter through the point A is making an angle of 45° with the VP. Measure the angle of the plane with the H.P.

- Q-4 Attempt all questions (14)**
- A** A cone of diameter of base 45 mm and axis length equal to 50 mm rests on a point on its base circle on H.P. such that its axis is inclined at an angle of 30° with the H.P. and its top view makes 45° with the V.P. Draw the projections. **07**
- B** A square prism of side of base equal to 40 mm and axis height 110 mm rests on one of its corner of its base on H.P. such that the axis is inclined at an angle of 40° with H.P. and 60° with the V.P. Draw its projection. **07**
- Q-5 Attempt all questions (14)**
- A** A straight line AB, 65 mm long has its end A 20 mm above H.P. and 25 mm in front of the V.P. The end B is 40 mm above the H.P. and 65 mm in front of the V.P. Draw the projections of AB. **07**
- B** Draw the projections of a line AB when its end A is 20 mm above H.P. and 10 mm in front of V.P. its end B is 55 mm above H.P. and 60 mm in front of V.P. and distance between projectors of A and B is 45 mm. Find True length and true inclination of line AB with H.P. and V.P. **07**
- Q-6 Attempt all questions (14)**
- A** Draw the development of lateral surface of a right circular cone having base diameter 40 mm and length of axis 60 mm, when it is resting on H.P. and cut by an AIP inclined at 45° to the H.P. and bisecting the axis. **07**
- B** A cone, base 40 mm diameter and axis 60 mm long, rests on its base on the HP. It is cut by a section plane perpendicular to the VP and parallel to one of its generators and passing through a point on the axis at a distance of 25 mm from the apex. Draw the front view, sectional top view, and the true shape of the section. **07**
- Q-7 Attempt all questions (14)**
- A** Explain with illustration following AutoCAD commands. **07**
 (i) Line (ii) Rectangle (iii) Ellipse (iv) Offset
 (v) Polygon (vi) Arc (vii) Circle Mirror
- B** Draw front view, top view and left hand side view of the object shown in Figure-2 according to first angle projection method. **07**
- Q-8 Attempt all questions (14)**
- A** List the application of AutoCAD in the industry. **07**
- B** Figure -3 shows the front view and top view of an object. Draw isometric view. **07**



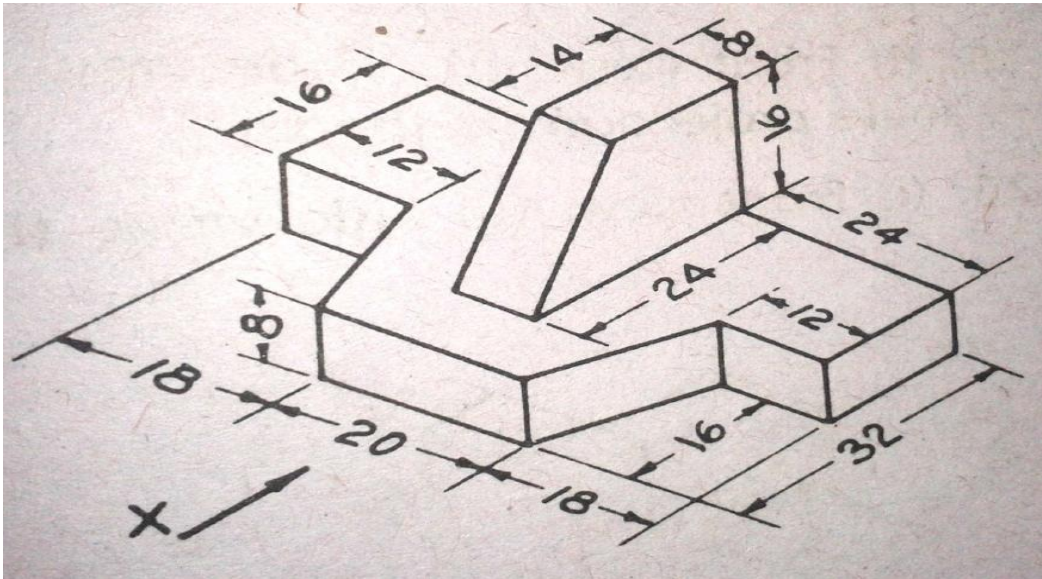

Fig. 1

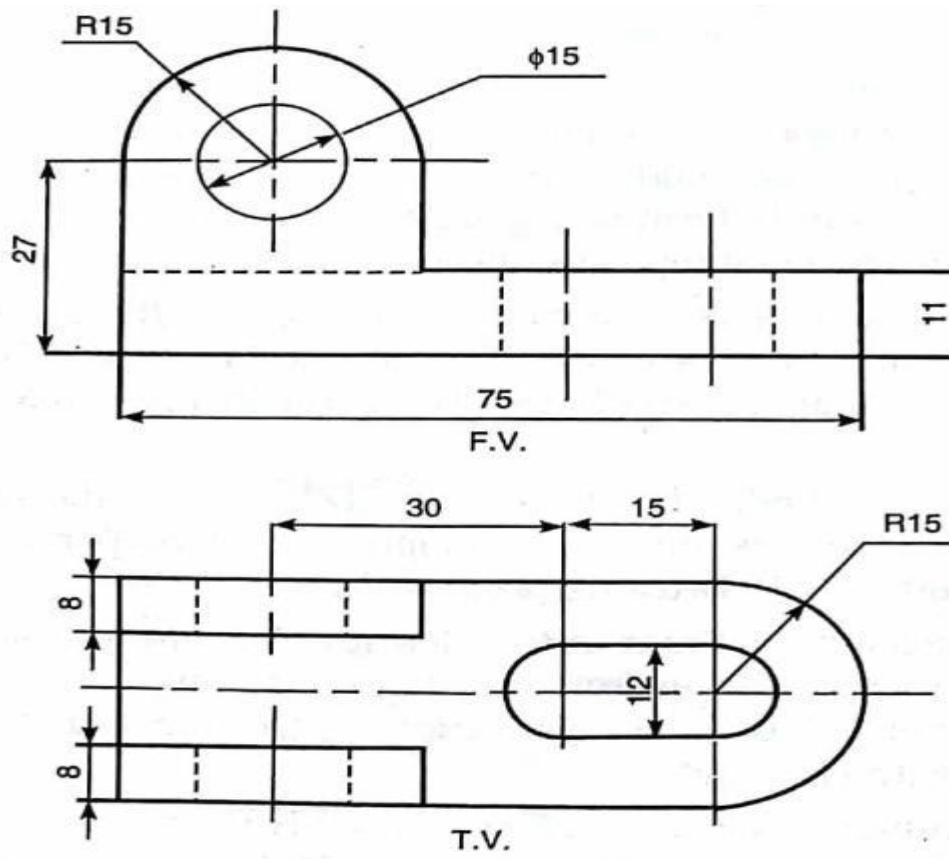

Fig. 2